

Customer Requirements Pole Conduit Riser

C-UG-1200

Application

Installation requirements for conduit risers installed on Tacoma Power poles.

In this Standard

Topic	Page
Terms	1
Responsibilities and Inspections	1
Conduit Requirements	2
Standoff Bracket Requirements	2
Installation Practices	3-4
Quantity of Risers	3
Riser Location	3
Construction Notes	4

Terms

Term	Definition
Construction Inspector	Representative from Tacoma Power T&D Construction Staff. A pre-construction meeting with the Construction Inspector must happen prior to any construction. CALL 253-381-3023
New Services Engineer	Tacoma Power engineering staff that provide design, cost estimates, and coordination of the commercial project.

Responsibilities and Inspections

Construction Area	Responsibility	Inspection by
Identifying the pole and location of the riser	<i>The New Services Engineer</i> will work with the Customer's Electrical Contractor to determine the location for the riser on Tacoma Power's pole.	Construction Inspector
Work in Road Right-of-Way	The Customer's Electrical Contractor will be responsible for installing conduit in the road right-of-way per the requirements of the permitting agency. Permits to cut and restore the road and any other work in the road right-of-way <u>must</u> be obtained before work in the right-of-way can begin. A copy of the approved permit must be on site while the road work is being done.	Construction Inspector
Installation of the first ten feet of the pole conduit riser	Customer's Electrical Contractor	Construction Inspector
Completion of the pole conduit riser	Tacoma Power T&D Construction Staff	Not needed

Customer Requirements Pole Conduit Riser

C-UG-1200

Conduit Requirements

- Conduit size shall be 2.5", 4", 5", or 6" as directed by New Services Engineer.
- The first 10 feet of the riser shall be Sch. 80 PVC, gray.
- The remaining portion of the riser shall be Sch. 40 PVC, gray.
- All conduit and elbows shall meet the requirements of the most recent edition of ASTM F512, NEMA TC-2 and UL 651. All elbows shall be factory made.
- The minimum radius of elbows used in all pole riser conduit installations, unless otherwise specified by the **Construction Inspector**, shall be:

TRADE SIZE	2.5"	4"	5"	6"
Elbow Radius	36"	36"	48"	48"

Standoff Bracket Requirements

Tacoma Power has the following requirements for standoff brackets (see Figure 1):

- Hot dip galvanized with 1-5/8" C channel, 15 to 24 inch length.
- 2-piece steel galvanized binding member clamps suited to conduit size and type. Wire clamps are not acceptable.
- Fit bracket closely to pole shape by bending straps before lag-bolting and firmly lag-bolt to pole.

Figure 1

Standoff Bracket Requirements

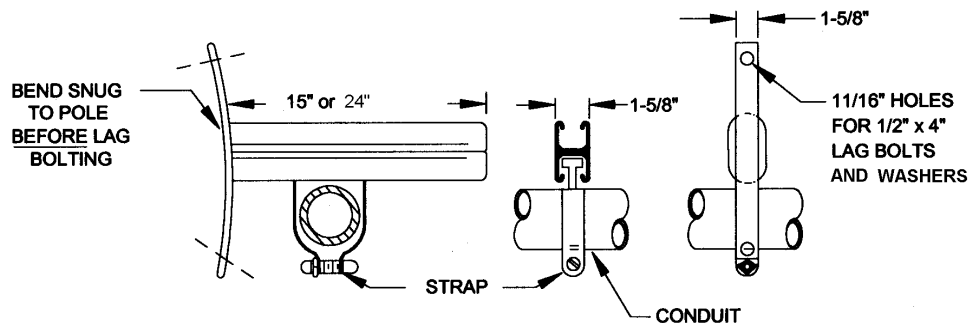

Customer Requirements Pole Conduit Riser

C-UG-1200

Installation Practices

Quantity of Risers The total quantity of conduits on a pole for all the utilities shall not be more than 6 (six). If additional space is required for risers, contact the **Construction Inspector**.

- Riser Location**
- If standoff brackets are already installed on the pole, the new riser(s) shall be attached to these standoffs.
 - If a riser is not already on the pole, the **Construction Inspector** must approve the riser location.
 - When practical, risers will be located on the field side of the pole, and the pole quadrant most protected from traffic. See Figure 2.

Figure 2 Pole Conduit Riser Location Opposite of Direction of Traffic

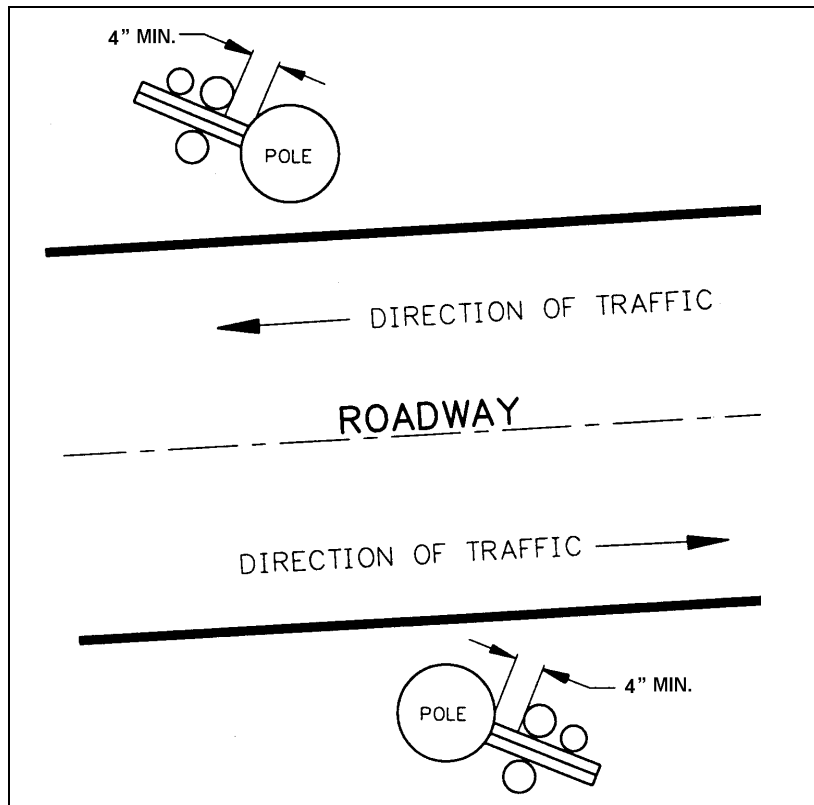

Customer Requirements Pole Conduit Riser

C-UG-1200

Installation Practices *(continued)*

Figure 3 Typical Riser Assembly

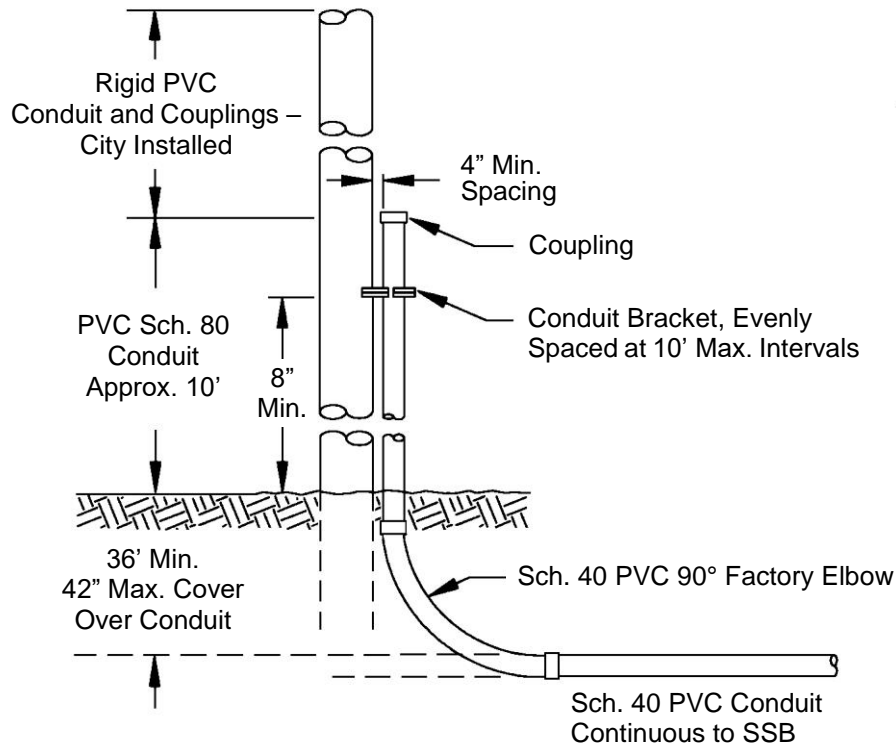

Construction Notes

- When excavating at the base of the pole, contact the **Construction Inspector**. No more than 1/4 of pole circumference and no more than 1/2 of the pole's buried depth may be exposed during excavation. Poles are set at 10% of the total pole length plus 2 feet.
- A full 10 foot piece of rigid Sch. 80 PVC conduit shall be the first section of conduit up the pole to at least 8 feet above the ground line.
- The lowest standoff bracket must be no closer than 8 feet to the ground, or other accessible surface.
- Conduits will be supported by brackets evenly spaced along the pole and no more than 10 feet apart.
- All conduits shall be temporarily capped with plastic caps or plugs, not tape.
- Spacing between the pole and conduit riser shall be a minimum of 4 inches.
- Maintain a 1 inch separation between risers to allow for cable locating equipment.
- If more than one conduit will be on the same side of the bracket, the higher voltage will be closest to the pole.
- The entire length of conduit riser should parallel the structure or pole, regardless of taper of the pole.