



Customer Requirements
Pole Attachment Requirements for
Telecommunications (non-RF)

C-OH-1060

Application

This standard establishes the attachment requirements to utility pole structures owned and operated by Tacoma Power and communication facilities owned and operated by others. This standard does not apply to antennas or other radio frequency (RF) emitting communication devices.

In This Standard

Topic	See Page
Terms	2
Attachment Requirements	2 - 8
Agreements, Permits and Codes	2
Order of Cable Attachment	4
Climbing Space	4
Cables, Messengers, Guys and Anchors	5
Risers	6
Tagging	7
Tag Specifications	7
Pole Drilling	8
Enclosure Mounting	8 - 11
Site Selection	8
Selection Criteria for Enclosures on Pole	8
Location of Enclosures on Pole	9
Ground Mounted Equipment	9
Electrical Inspection	9
Labeling	10
Grounding Requirements	12 - 13
Metallic Messenger Bonding	12
Nonmetallic Messengers	12
Enclosure Grounding	13

Customer Requirements Pole Attachment Requirements for Telecommunications (non-RF)

C-OH-1060

Terms

The following are definitions of terms used in this standard (see Figure 1):

Term	Definition
Joint Utility	For the purposes of this standard, any entity (utility, public agency, telecom company, or other) other than the electrical supply utility that is attached to the structure.
Communication Space	The space on joint-use structures where communication facilities are separated from the supply space by the communication Worker safety zone. This space is below the communication worker safety zone.
Communication Worker Safety Zone	That space as defined in National Electric Safety Code (NESC) Rule 235C4. This zone generally originates at the lowest point of the supply space. This space is intended to maintain a physical separation between supply and communication facilities. The minimum dimensions of this space shall at no time be violated.
Supply Space	The space on joint-use structures where supply facilities are separated from the communication space by the communication worker safety zone. This space is above the communication worker safety zone.
Distribution	Tacoma Power supply voltages of 7.2 kV to 15 kV.
Secondary	Tacoma Power supply voltages of 600 V or less.
Supply Neutral	Multi-grounded conductor for the supply system.

Attachment Requirements

Agreements, Permits and Codes

- Prior to attaching equipment to poles owned by Tacoma Power, a pole attachment agreement must be signed by all parties involved and the related pole attachment permit approved. Please contact Tacoma Power *Business and Financial Mgmt Dept* at pwjointutilities@cityoftacoma.org.
- All attachments must meet the requirements for clearance and strength as specified by standard C-OH-9000 "Customer Requirements, Clearance Requirements for Overhead Joint Utility Construction" and the NESC, along with statutory, code, and other regulatory requirements established by the State of Washington, Pierce County, and local governments including the City of Tacoma.
- Attachments within the city limits of Tacoma must comply with the requirements of City of Tacoma Municipal Code, Title 16 and City of Tacoma franchise agreement.

Customer Requirements
Pole Attachment Requirements for
Telecommunications (non-RF)

C-OH-1060

Attachment Requirements *(continued)*

Figure 1 Illustration of Space Allocation on Pole

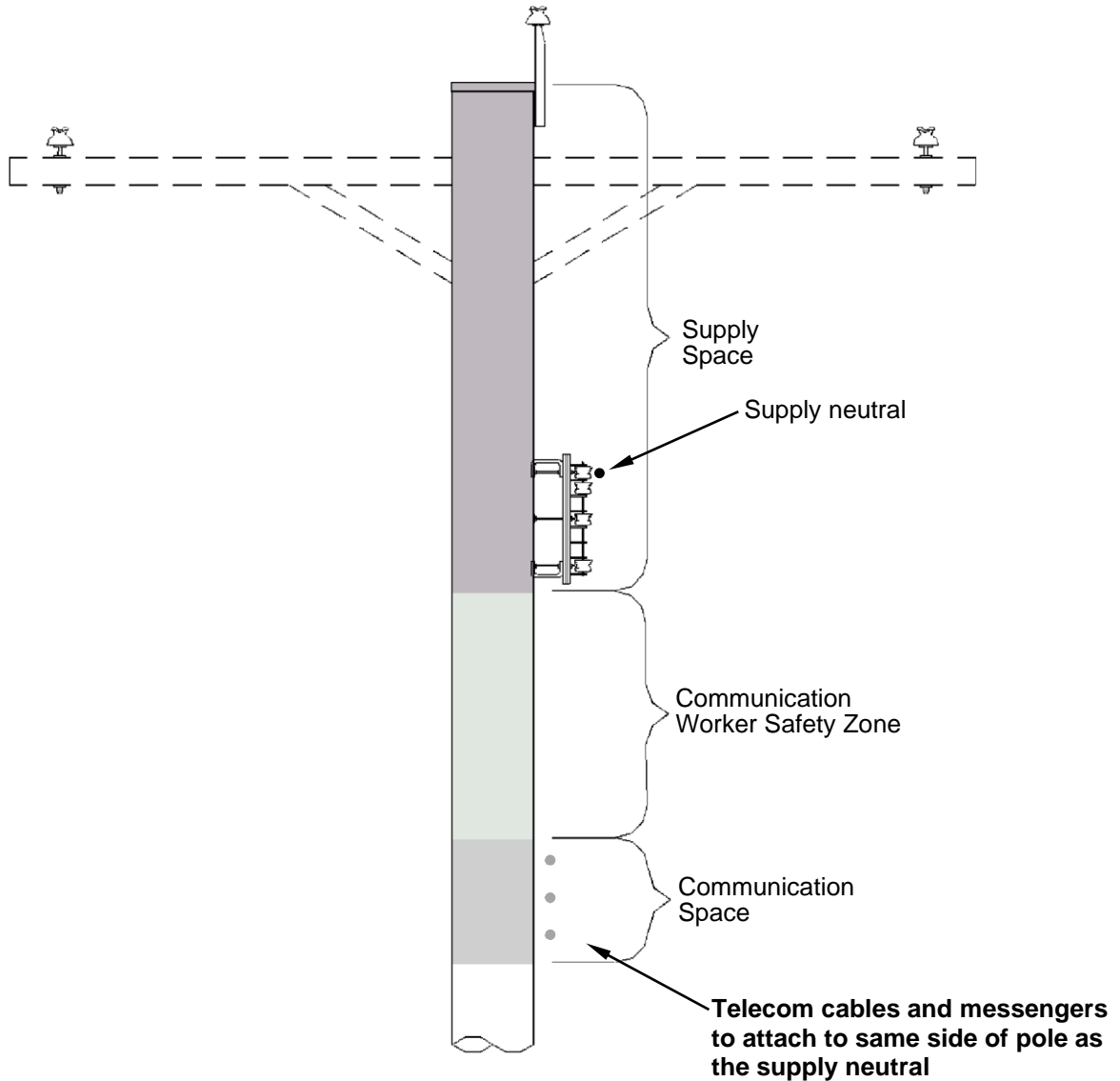

Customer Requirements Pole Attachment Requirements for Telecommunications (non-RF)

C-OH-1060

Attachment Requirements *(continued)*

Order of Cable Attachment

On poles owned by Tacoma Power and those co-owned with Century Link Communications (formerly known as: Qwest), the order of telecom cable attachments will be as follows (see Figure 2):

- Top attachment shall be Tacoma Power/Rainier Connect (TP/RC)
- Below (TP/RC) – Tacoma Fire
- Middle attachments other attachees
- Lowest attachment shall be Century Link (if present)

Figure 2

Cable Attachment Clearances on Pole in Communication Space

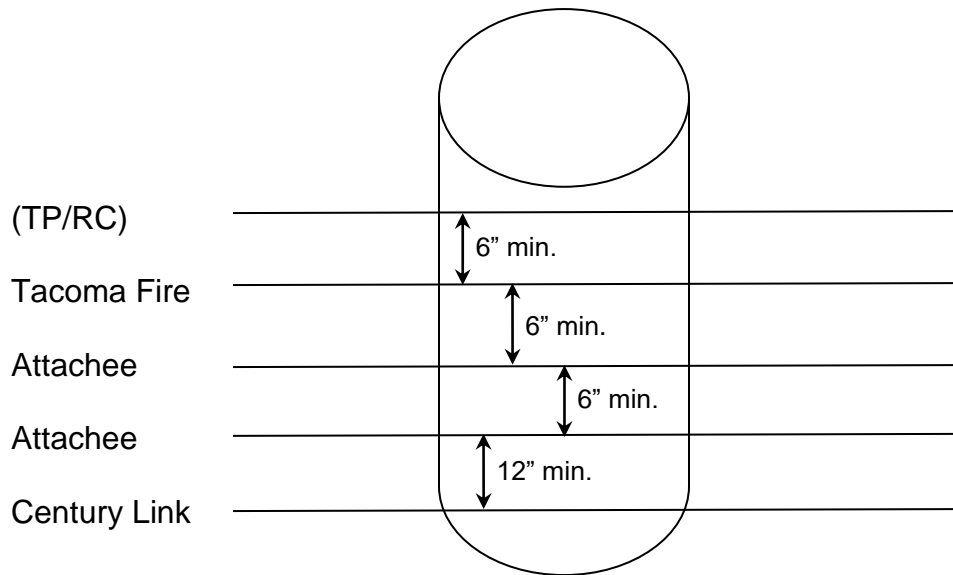

Climbing Space

Unless specifically designated by Tacoma Power, all poles shall be climbable to the requirements of the NESC.

Customer Requirements
Pole Attachment Requirements for
Telecommunications (non-RF)

C-OH-1060

Attachment Requirements *(continued)*

**Cables,
Messengers,
Guys and
Anchors**

Requirements for joint utilities' cables, messengers, guys and anchors.

For...	Do This...
Cables and Messengers	<ul style="list-style-type: none"> • Attach to the same side of the pole as the supply neutral (see Figure 1). • If the supply neutral is on a crossarm, then the telecom cables shall be installed on the road side of the pole. • Telecom attachments shall maintain 6 to 12 in. minimum vertical separation from each other according to the NESC (see Figure 2). • Always attach below the "DO NOT ATTACH ABOVE THIS TAG" sign. 
Cables, Messengers, Guys and Anchors	<p>Tension and/or guy the cable and/or messenger so that:</p> <ul style="list-style-type: none"> • the angle of the existing structures is not altered. • pole buckling does not occur. • the sag characteristics of the supply conductors and existing telecom conductors are not altered. <p>Also:</p> <ul style="list-style-type: none"> • Install anchors no closer than 6 ft. to another anchor. • Attachment to existing Tacoma Power anchors will require prior approval by Tacoma Power.

Customer Requirements
Pole Attachment Requirements for
Telecommunications (non-RF)

C-OH-1060

Attachment Requirements *(continued)*

Risers

Telecom and service wire installed vertically on the pole shall be in a conduit riser. Conduit risers shall follow the requirements below (see Figures 4 and 5):

- Risers shall be installed on standoff brackets and the brackets shall be:
 - no lower than 8 ft. from the ground or other accessible surface.
 - mounted within 6 in. of the top end of any stick of conduit.
 - evenly spaced along the pole and no more than 10 ft. apart.
- If standoff brackets are already installed on the pole, the new riser(s) shall be attached to these standoffs.
- Spacing between the pole and conduit riser shall be a minimum of 4 in.
- The entire length of conduit risers should parallel the structure or pole, regardless of taper of the pole.
- The total quantity of conduits on a pole for all the utilities shall not be more than six.
- Conduit shall be continuous into enclosure.
- Service riser conduit shall be no smaller than 1-1/4 in. sch. 40 PVC.
- The conduit can be extended to but no closer than 40 in. of the supply space.
- The additional conduit, weatherhead, conductor, and standoff brackets required to extend the service riser into the supply space shall be supplied on the pole for Tacoma Power to complete. Confirm with *Tacoma Power T&D Construction Office*



Customer Requirements Pole Attachment Requirements for Telecommunications (non-RF)

C-OH-1060

Attachment Requirements *(continued)*

Tagging Telecom companies are required to install a tag on their cables ***at each pole***. This benefits crews during pole replacements, repairs, and emergency service providers during emergencies. Tacoma Power has assigned identification codes to the organizations (identical to Seattle City Light, when applicable) as listed below.

Code	Organization	Code	Organization
001	TP/RC/U.P. School District	019	City of Fircrest
002	Tacoma Fire	020	City of Fife
003	Tacoma Traffic Signal	021	City of Tacoma Communications
004	Comcast	022	PSE
005	Qwest/CenturyLink	023	Unite Private Networks
006	Rainier Group	024	Cellnet
007	Port of Tacoma	025	FatBeam
008	Clover Park School District	026	AT&T
009	Franklin Pierce School District/EMAN	027	Astound/Wave Broadband
010	Bethel School District	028	MCImetro
011	Pierce County	029	Pierce Transit
012	City of Lakewood	030	WanRack
013	City of University Place	047	Crown Castle Fiber
014	ZAYO (formerly Integra)	158	Exenet Systems
015	Sprint		
016	ZAYO		
017	Tacoma Water		
018	University of Washington		

Tag Specifications

Cable Identification tags shall be:

- Black on yellow (black numbering on yellow background).
- Minimum 2 in. x 3 in. size tags with numbers minimum 1 in. height.
- Non-conductive, UV resistant polyethylene.

Customer Requirements Pole Attachment Requirements for Telecommunications (non-RF)

C-OH-1060

Attachment Requirements *(continued)*

Pole Drilling To maintain structural integrity of the pole, holes drilled into poles shall follow the table below (see Figure 3).

Activity	Description
Holes on same side of pole	Holes on same side of pole shall be no closer than 6 in.
Holes perpendicular to each other	Holes that are perpendicular shall be no closer than 3 in.
Hole Treatment	<ul style="list-style-type: none"> • Douglas Fir Poles: Treat holes with Tacoma Power's current approved preservative. • Cedar Poles: Do not require treatment.

Figure 3 Pole Drilling

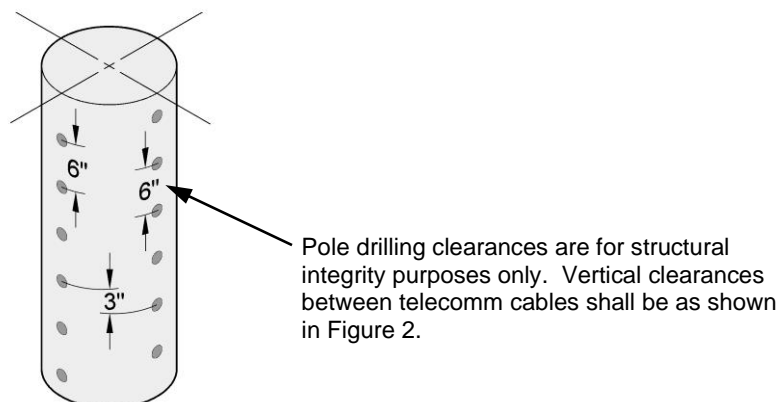

Enclosure Mounting

Site Selection Pole locations selected for enclosure attachment shall be forwarded to the Tacoma Power *New Services Engineering Office* for review. Pole attachments are approved on a pole-by-pole basis and Tacoma Power reserves the right to deny attachment to any pole.

Selection Criteria for Enclosures on Pole

- Enclosures ***should*** be mounted on clean tangent poles when possible.
- Enclosures ***should not*** be mounted on poles that are in the following conditions:
- Deadend or double deadend corner poles with or without anchors
 - Poles that have supply buck leads (distribution lines extending in three directions)
 - Poles with switch handles that extend below the communication space
 - Feeder Getaway/Terminal poles with power cable risers and hook operated switches.
 - Poles that have existing equipment boxes such as:
 - control boxes for Tacoma Power equipment
 - other power supply, battery, etc.

Customer Requirements
Pole Attachment Requirements for
Telecommunications (non-RF)

C-OH-1060

Enclosure Mounting *(continued)*

Location of Enclosures on Pole

Enclosure mounting shall follow requirements listed below (see Figures 4 & 5):

- Mount under the transformer or other pole device.
- If transformer or other pole device does not exist, then mount enclosure in line with the OH distribution conductors and under the distribution crossarm. In the absence of a crossarm, mount enclosure under the distribution conductor and on the gain or pole tag side of the pole.
- Bottom of enclosure shall be 15 ft. above grade.
- No closer than 4 in. from the surface of the pole.

Ground Mounted Equipment

- Subsurface handholes and ground mounted pedestals should be:
 - located on the road or field side of the pole or grouped with any existing handholes/pedestals.
 - a minimum 4 ft (6 ft to 10 ft preferred) from base of pole.
- Do not install handholes/pedestals or underground conduit in the pole line where it would conflict with the future replacement of the pole.
- When the equipment must be placed in line with the pole, it should be located on the transformer, distribution crossarm, or other power equipment side of the pole.
- Ground mounted equipment shall follow the requirements of C-SV-3200 “Customer Requirements, Commercial Secondary Service”.

Electrical Inspection

Electrical service for enclosures shall be inspected and approved by the Tacoma Power Electrical Inspection Office prior to energization.

Enclosure Mounting *(continued)*

Figure 4 Attachment Requirements for Enclosures and Risers

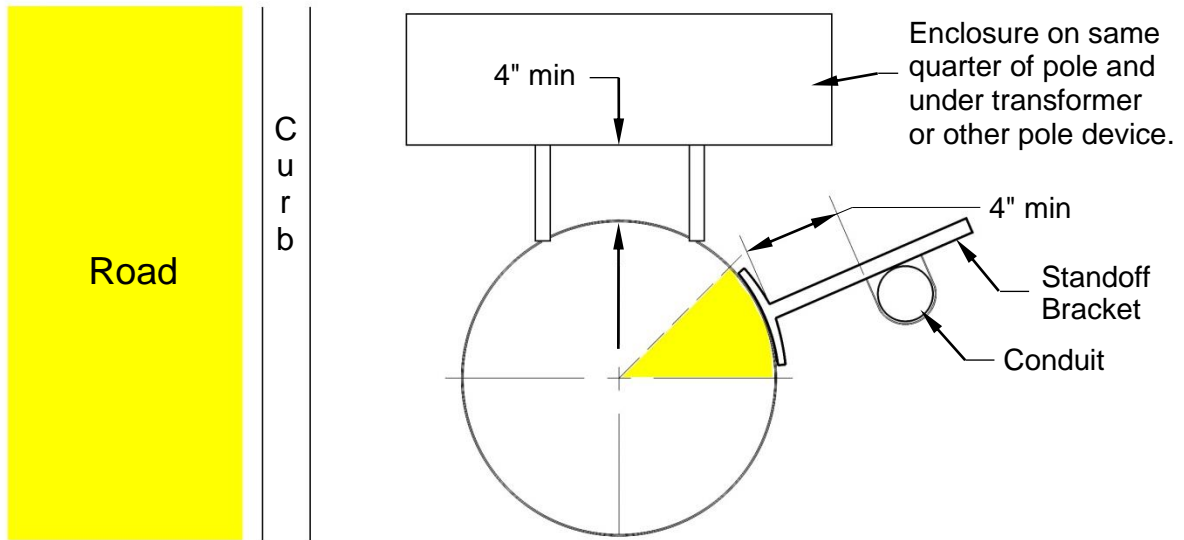

Labeling

Enclosures shall be labeled as follows:

- Clearly labeled with reflective, weather and UV resistant sign or decal on the road side surface of the enclosure.
- Label shall have the following information:
 - Name of owner
 - Reference, site or equipment ID number
 - 24 hr phone number to responsible person that will respond to emergencies in a timely manner

NOTE: Reference numbers along with the physical address of each enclosure installation must be included with the application for electrical service.

Customer Requirements
Pole Attachment Requirements for
Telecommunications (non-RF)

C-OH-1060

Enclosure Mounting *(continued)*

Figure 5 Pole Mounting of a Telecom Enclosure and Service Riser by Non-Qualified Electrical Workers.

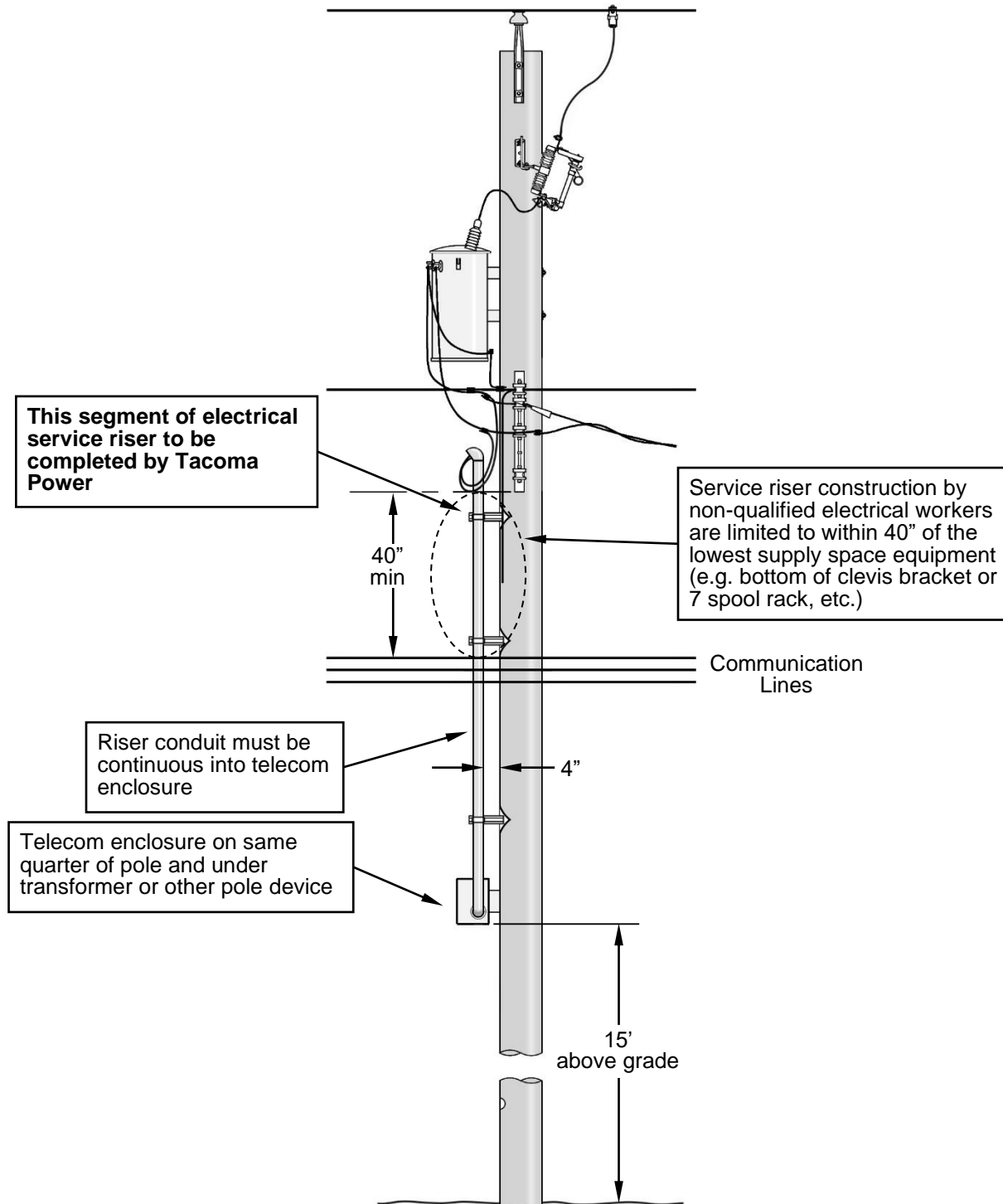

Customer Requirements Pole Attachment Requirements for Telecommunications (non-RF)

C-OH-1060

Grounding Requirements

Metallic Messenger Bonding

Metallic and/or conductive messengers shall be bonded to the pole grounds as listed below:

Activity	Description
Number of bonding points	The messengers shall be bonded per the requirements of the NESC to the pole ground.
Who makes the bonding connection?	The attaching utility shall make and maintain all bonding connections for their messengers and equipment.
Who supplies the pole ground?	Tacoma Power installs and maintains all pole grounds.

Nonmetallic Messengers

Bonding requirements of messengers are governed by the NESC. If the messenger meets the requirements of the NESC as nonconductive (Kevlar-type), bonding is not required.

Figure 6 Grounding of Telecom Conductors at Supports

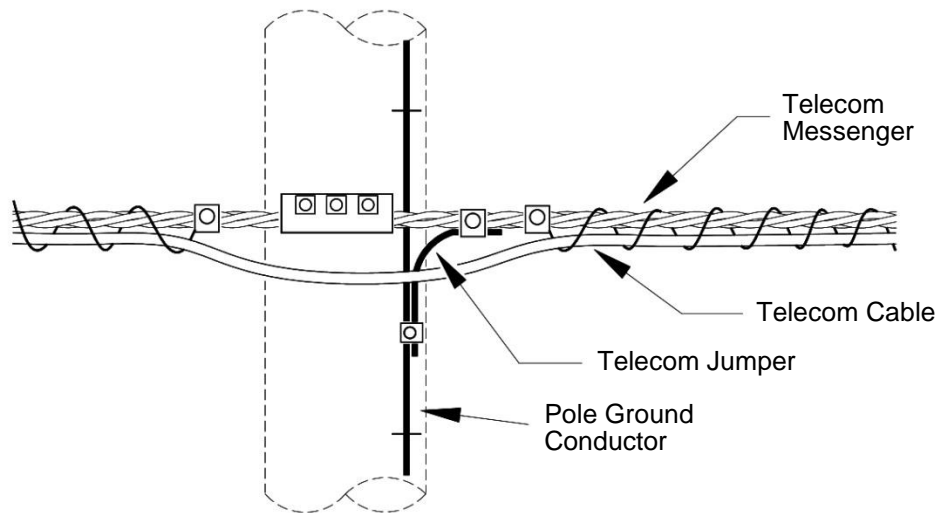

Customer Requirements
Pole Attachment Requirements for
Telecommunications (non-RF)

C-OH-1060

Grounding Requirements *(continued)*

Enclosure Grounding

- All enclosures shall be bonded to existing pole grounds.
- Enclosures requiring electrical service (amplifiers, power supplies) shall be grounded per National Electric Code (NEC) (see Figure 7).

Figure 7 Grounding of Enclosures

